



OcNOS

Modernize Your Data Center with EVPN-VxLAN on OcNOS

April 2024

IP Infusion Solutions for Enterprise, Managed Service Provider (MSP) and Cloud Service Provider (CSP) Data Centers.

Planning your next data center upgrade and seeking ways to support scalable, containerized applications and leverage hybrid cloud services? As a data center operator committed to modern business needs, you require a network built for dynamic adaptation, centralized control, seamless workload migration across data center and cloud environments, and cost-optimized scaling. IP Infusion OcNOS delivers this foundation, empowering you to transform your data center and drive success.

OcNOS Powers Modern Data Centers

IP Infusion OcNOS delivers open standards and open disaggregated networking solutions with a strong focus on EVPN-VxLAN, driving agility, efficiency, and scalability for your business.

Secure Multi-Tenancy

Create large-scale, logically isolated network segments with EVPN-VxLAN, ensuring secure environments for multiple tenants or work groups. EVPN provides the control plane for MAC address learning, route distribution, and network virtualization, while VxLAN encapsulates Layer 2 Ethernet frames within Layer 3 UDP packets for transporting over IP fabric underlay that is inherently stable and scalable.

OcNOS can auto discover overlay tunnel endpoints and end-host reachability from EVPN's MP-BGP route advertisements, simplifying network deployment and ensuring security. The segmentation of the virtual networks enhances security by restricting traffic flow between all connected devices in the network.

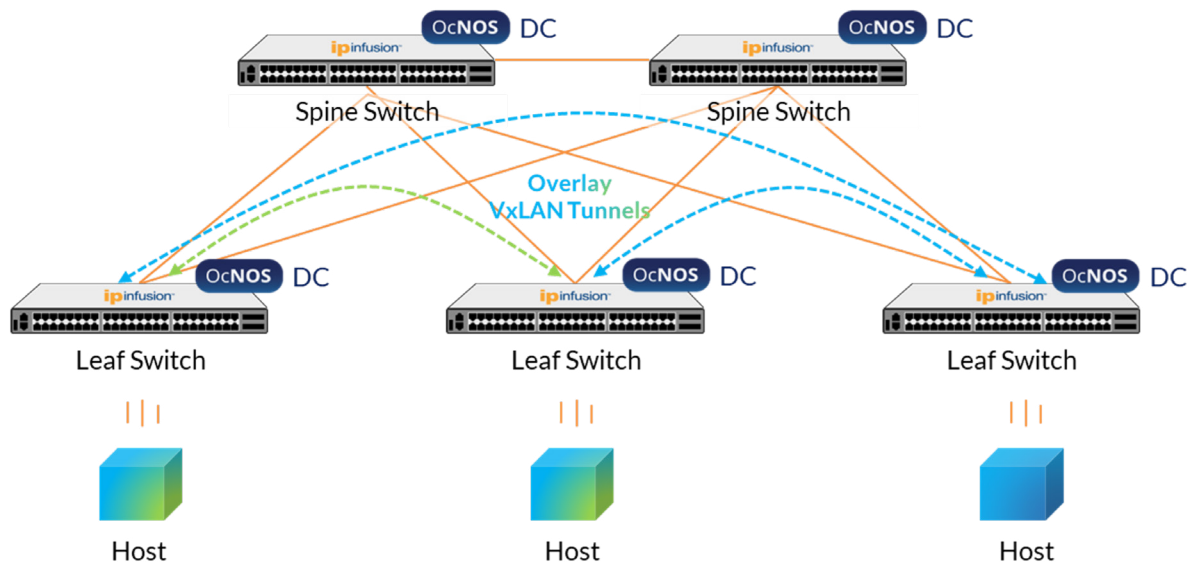

Figure 1. EVPN VxLAN Overlay with OcNOS

Microservices and Containerization

Enterprises, MSPs and CSPs alike are embracing containerization technologies like Docker and orchestration platforms like Kubernetes to enable scalable and portable application deployments within data center environments.

EVPN-VxLAN is essential for facilitating communication between distributed workloads. Overlay networks created by EVPN-VxLAN enable containers to communicate across hosts and environments while maintaining isolation and security.

In Kubernetes, load balancing is a critical component for distributing incoming network traffic across multiple instances of an application to ensure high availability, scalability, and reliability. OcNOS supports overlay Equal Cost Multipath (ECMP) to utilize the entire IP fabric to efficiently distribute the traffic to a Kubernetes cluster. Furthermore, utilizing the BGP Additional Path (ADD-PATH) feature, OcNOS allows BGP route reflectors (RR) to be configured inside the Kubernetes cluster to minimize the BGP neighbors to each EVPN-VxLAN VTEP leaf switch for higher scalability while forming the ECMP paths for as many Kubernetes workers advertising the same virtual IP (VIP).

Learn more about Overlay ECMP on OcNOS in our latest blogs:

- [Overlay ECMP on OcNOS Part-1](#)
- [Overlay ECMP on OcNOS Part-2](#)

Integration of Private Cloud with Public Cloud for Hybrid Environments

EVPN-VxLAN abstracts underlying physical networking infrastructure and facilitates seamless connectivity between on-premises data centers and public cloud environments. By extending virtual networks from on-premises environments to the cloud using EVPN-VxLAN overlay technologies, organizations can establish hybrid connectivity models that enable seamless workload migration, data replication, cross-cloud communication, disaster recovery, and distributed application architectures.

New Data Center Interconnect (DCI) technologies like IP over DWDM with 400G ZR/ZR+ enable high-speed, low-latency connectivity between an on-premises (on-prem) data center and the interconnection point where Direct Connect service is available to connect to major public cloud service providers. It can also link up data centers within metro distances up to 90+ km in a single span without the added cost of amplifiers.

VENDOR	SKU	TYPE	FORM FACTOR	INTERFACE (G)	REACH
Ciena	IPI-CI-176-3530-901	ZR	QSFP-DD	400	120km
Fujitsu	IPI-FU-FIM38900/120	ZR	QSFP-DD	400	120km
SmartOptics	IPI-SO-TQSFP-DD-4CCZRP	ZR+	QSFP-DD	400	480km
SmartOptics	IPI-SO-TQD013-TUNC-SO	ZR+	QSFP-DD	400	480km
Hisense Broadband	IPI-HBLCQ638BS-PC+	ZR+	QSFP-DD	400	480km
Ciena	IPI-CI-176-3580-900	ZR+	QSFP-DD	400	480km
Coherent Corp	IPI-CO-FTCD3323R1PCL	ZR+	QSFP-DD	400	480km

Table 1. OcNOS Qualified 400G ZR/ZR+ Transceivers

VENDOR	MODEL	APPLICATION	FORM FACTOR	25G SFP28	100G QSFP28	100G QSFP-DD	400G QSFP-DD
UfiSpace	S9510-28DC	Access, Aggregation, Edge Router	1 RU	24	2		2
Edgecore	AS7535-28XB	Access, Aggregation Router	1 RU	25	2		2
Edgecore	AS7946-30XB	Access, Aggregation Router	2 RU	4	18	4	4
UfiSpace	S9600-28DX	Aggregation, Edge Router	2 RU		24		4
UfiSpace	S9600-56DX	Aggregation, Edge Router	2 RU		48		8
UfiSpace	S9610-36D	Aggregation, Edge Router	2 RU				36

Table 2. OcNOS Qualified Hardware Platforms with 400G ZR/ZR+ Transceiver Support

Open Standards

Open standards define common protocols, interfaces, and formats that enable different devices and systems from multiple vendors to work together seamlessly. Collaborative efforts within open standards organizations lead to the development of consensus-based specifications and reference implementations that benefit the entire ecosystem.

IP Infusion fully embraces and adheres to open standards principles and builds the data center solution based on EVPN-VxLAN open networking standards. Organizations can future-proof their network infrastructure and avoid vendor lock-in by adopting the IP Infusion OcNOS data center solution to ensure long-term flexibility and scalability. In a rapidly evolving networking landscape, open standards and open

networking enable organizations to adapt to technological advancements, market shifts, and emerging trends more effectively.

Organizations should move away from vendor-specific solutions and go to open standards. RFCs are great references for how things should work and how vendors are supposed to interoperate.

Open, Disaggregated Networking

Open disaggregated networking offers organizations greater flexibility, choice, and control over their network infrastructure. It decouples network hardware and software, allowing organizations to choose components from different vendors and customize their network infrastructure based on their specific requirements and preferences.

Data center modernization in 2024 inevitably involves upgrading to 400G and even 800G networks. Proprietary solutions often come with exorbitant hardware, licensing, and support expenses, hindering the extent your budget can get you. You need to upgrade quickly to stay ahead of the curve. Time is of the essence when it comes to competitive edge. By decoupling hardware and software, organizations can avoid vendor lock-in and negotiate better pricing and lead times for individual components, potentially leading to substantial cost savings and much faster time to market.

IP Infusion's embrace of open networking principles empowers you to build truly adaptable and future-ready networks flexibly. With white box switches, you unlock:

VENDOR	MODEL	ASIC	SERVICE CAPACITY	FORM FACTOR	PORT CONFIGURARION	BUFFER
Celestica	DS1000	TD3-X2	128Gbps	1 RU	48x 1G RJ45, 8x 10G SFP+ Management/Leaf Switch	4 MB
UfiSpace	S6301-56ST	TD3-X2	128Gbps	1 RU	48x 1G RJ45, 8x 10G SFP+ Management/Leaf Switch	4 MB
Edgecore	AS5835-54T	TD3-X5	1.08Tbps	1 RU	48x 10G RJ45, 6x100G QSFP28 Management/Leaf Switch	32 MB
Edgecore	AS5835-54X	TD3-X5	1.08Tbps	1 RU	48x 10G SFP+, 6x100G QSFP28 Management/Leaf Switch	32 MB
UfiSpace	S8901-54XC	TD3-X5	2Tbps	1RU	48x 25G SFP28, 6x100G QSFP28 Leaf Switch	32 MB
Edgecore	AS7326-56X	TD3-X5	2Tbps	1 RU	48x 25G SFP28, 8x100G QSFP28 Leaf Switch	32 MB
Celestica	DX030	TD3-X7	3.2Tbps	1 RU	32x 100G QSFP28, Leaf/Spine Switch	32 MB
Edgecore	AS7726-32X	TD3-X7	3.2Tbps	1 RU	32x 100G QSFP28, Leaf/Spine Switch	32 MB
UfiSpace	S9110-32X	TD3-X7	3.2Tbps	1 RU	32x 100G QSFP28, Leaf/Spine Switch	32 MB
Edgecore	AS7712-32X	TH	3.2Tbps	1 RU	32x 100G QSFP28, Spine Switch	16 MB
Edgecore	AS7816-64X	TH2	6.4Tbps	2 RU	64x 100G QSFP28, Spine Switch	42MB
Edgecore	AS9716-32D	TH3	12.8Tbps	1 RU	32x 400G QSFP-DD, Spine Switch	64 MB

Table 3. OcNOS Qualified White Box Switches

Proprietary solutions typically force hardware + software combined support. For hardware replacement, the only options are 4-hour or next-business-day (NBD) replacement. The expensive annual support fee charged by the proprietary solution is typically enough to buy a spare hardware unit. With IP Infusion's disaggregated solution, not only there is an option to choose the hardware warranty as a separate, independent service from the software support and maintenance, but the customer can also choose to self-insure their own hardware by purchasing an extra piece of hardware that matches exactly the deployed unit. Customers can keep the spare unit hot in the lab as a ready standby unit to provide better replacement assurance than any 4-hour or NBD plan.

Summary

Investing the time and effort in future looking and innovative open standards and open disaggregated networking solutions such as IP Infusion's OcNOS solution that is based on EVPN-VxLAN should be a key aspect of an organization's data center modernization initiative.

Juggling multiple NOSes across your data center network to support different functions creates operational overhead, slows innovation, and increases the risk of interoperability. IP Infusion OcNOS provides a purpose-built solution tailored for your data center fabric and edge, as well as carrier network deployments. This reduces operational overhead by streamlining network management and minimizing the need for specialized expertise across different parts of your network.

Customer Perspective: Scott Data

Scott Data, a leading infrastructure services provider, leveraged IP Infusion OcNOS to transform their data center network to provide managed services including GPU-as-a-Service. Facing limitations with their legacy solution, they sought a more agile, scalable, and cost-effective approach. OcNOS delivered significant benefits:

- **Unmatched Speed of Deployment:** OcNOS shattered the limitations of proprietary lead times, reducing them from 60+ weeks to a mere four weeks. This unlocked rapid response to market demand and accelerated innovation.
- **Operational Efficiency Redefined:** The flexibility and scalability of OcNOS were game-changers for Scott Data. Disaggregation allowed them to choose the best hardware for their needs, and the intuitive management tools streamlined network operations. They highlighted the ability to scale services "in a way we've never seen in the past," enabling them to keep pace with evolving client demands.
- **Future-Proof Investment:** Scott Data prioritized a future-proof solution that could adapt to changing technologies and business needs. OcNOS, built on open standards, offered the flexibility they require. Its commitment to innovation ensures Scott Data's network remains a competitive advantage.
- **Reduced Total Cost of Ownership (TCO):** Scott Data realized a remarkable 1/6th of the TCO compared to their legacy network. These substantial cost savings empowered them to reinvest in a new piece of open hardware using just one year of traditional vendor support costs.

Streamline OcNOS Deployment and Support

IP Infusion goes beyond software, offering a comprehensive solution to simplify your network transformation journey:

- **Validated White Box Hardware:** Select from a range of validated white box switches, ensuring seamless compatibility and optimal performance with OcNOS.
- **Bundle of OcNOS and Switch with an Easy-to-order SKU:** Delivered with a platform ready binary image with one touch installation on the hardware.
- **Compatible Optics:** Access a wide range of compatible transceivers, eliminating compatibility concerns and vendor lock-in associated with proprietary solutions.
- **World-Class Support:** Benefit from IP Infusion's world-class support team, ensuring you receive the expertise needed to deploy, manage, and optimize your network effectively.



Figure 2. IP Infusion Pro and Fast Service Programs

This one-stop-shopping experience simplifies procurement, reduces complexity, and minimizes risks, allowing you to focus on accelerating innovation and delivering exceptional services to your clients.

Contact Us Today

Ready to break free from the constraints holding back your data center network? Discover the future with OcNOS. Learn how we can help you unlock innovation, optimize operations, and leave outdated solutions behind. **Contact us today to schedule a demo and chart a new course for your success.**

ABOUT IP INFUSION

IP Infusion is a leading provider of open network software and solutions for carriers, service providers and data center operators. Our solutions enable network operators to disaggregate their networks to accelerate innovation, streamline operations, and reduce Total Cost of Ownership (TCO). Network OEMs may also disaggregate network devices to expedite time to market, offer comprehensive services, and achieve carrier grade robustness. IP Infusion network software platforms have a proven track record in carrier-grade open networking with over 500 customers and over 10,000 deployments. IP Infusion is headquartered in Santa Clara, Calif., and is a wholly owned and independently operated subsidiary of ACCESS CO., LTD. Additional information can be found at <http://www.ipinfusion.com>

© 2024 IP Infusion, Inc. All rights reserved. IP Infusion is a registered trademark and the ipinfusion logo and OcNOS are trademarks of IP Infusion, Inc. All other trademarks and logos are the property of their respective owners. IP Infusion assumes no responsibility for any inaccuracies in this document. IP Infusion reserves the right to change, modify, transfer, or otherwise revise this publication without notice.

Phone | +1-877-699-3267 Email | sales@ipinfusion.com Web | www.ipinfusion.com